

FLOW CONTROL RANGE TABLE

CLASSIFICATION		FLOW CONTROL RANGE		LPM (GPM)	
Pipe Diameter (inch)	Paddle	Minimum		Maximum	
		On-Flow	Off-Flow	On-Flow	Off-Flow
1	1	15 (4.0)	8 (2.0)	45 (12.0)	41 (11.0)
1-1/4		26 (6.9)	13 (3.4)	75 (20.0)	68 (18.0)
1-1/2		29 (7.0)	20 (5.3)	105 (28.0)	94 (25.0)
2	2	34 (9.0)	17 (4.5)	120 (32.0)	105 (28.0)
2-1/2		60 (16.0)	34 (9.0)	210 (55.0)	188 (50.0)
3	3	68 (18.0)	30 (8.0)	288 (76.0)	275 (73.0)
4		128 (34.0)	64 (17.0)	412 (109.0)	360 (95.0)
5		225 (59.0)	113 (30.0)	750 (198.0)	652 (172.0)
6		345 (91.0)	172 (45.0)	1125 (297.0)	975 (258.0)

*This table illustrates the flow control range obtained from experimental data. A variation of up to 10% can be expected, depending on operating conditions. Final adjustments should be made on site using a flow meter

PRESSURE LOSS RATE

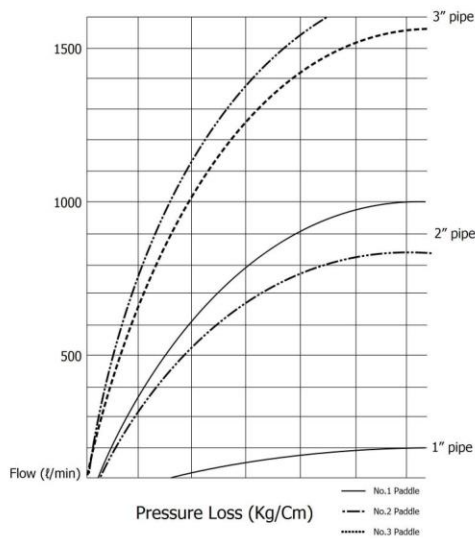

FLOW-VELOCITY

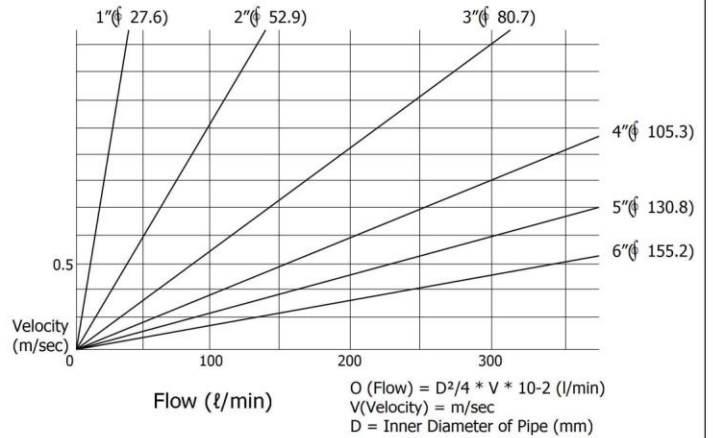

DIMENSION

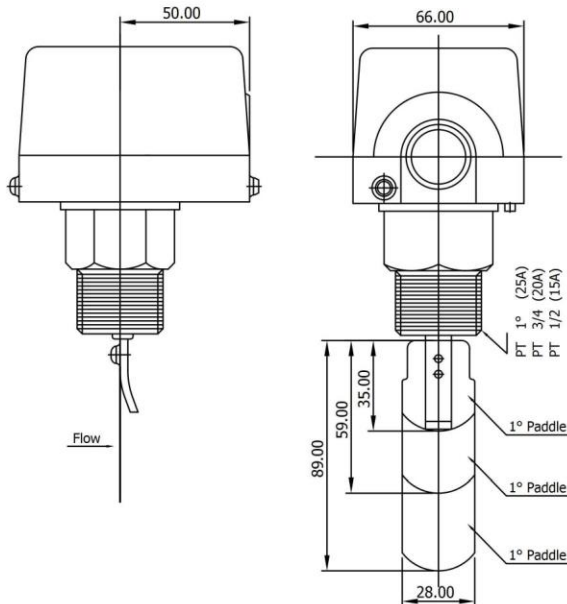

Typical Installation

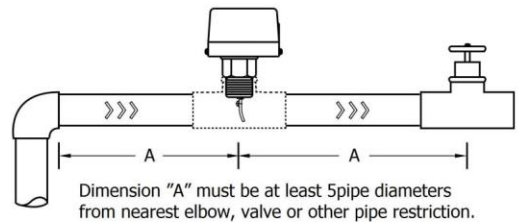

NO-FLOW

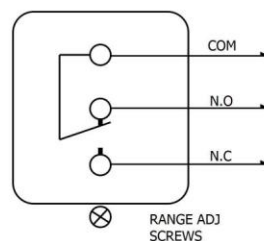

FLOW

