

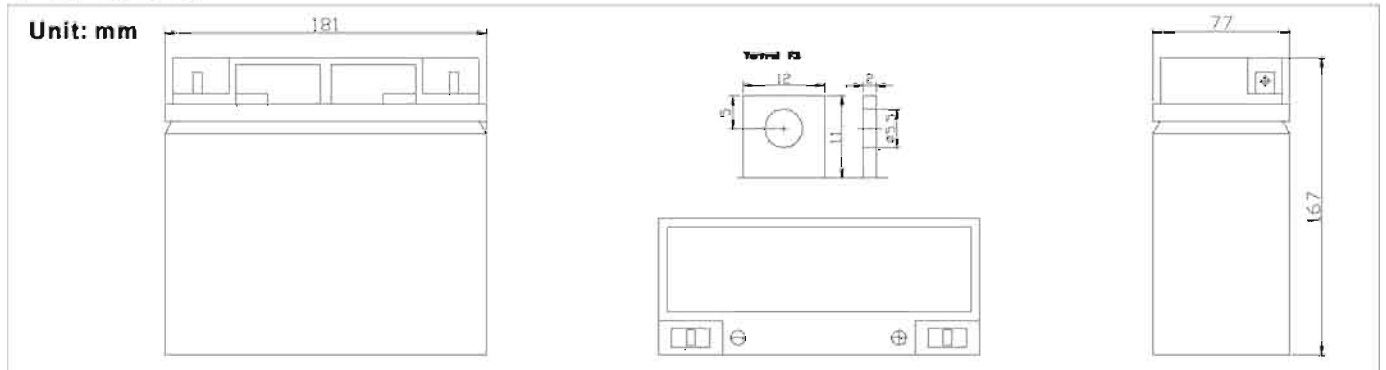

## Specification

Cells Per Unit	6
Voltage Per Unit	12
Capacity	18.0Ah@20hr-rate to 1.75V per cell @25°C
Weight	Approx. 5.3 Kg
Size (LxWxHxTotalH)	181 x 77 x 167 x 167 mm.
Max. Discharge Current	180 A(5 sec)
Internal Resistance	Approx. 14 mΩ
Operating Temperature Range	Discharge: -20°C~60°C Charge: 0°C~50°C Storage: -20°C~60°C
Normal Operating Temperature Range	25°C ± 5°C
Float charging Voltage	13.6 to 13.8 VDC/unit Average at 25°C
Recommended Maximum Charging Current Limit	5.4 A
Equalization and Cycle Service	14.5 to 14.9 VDC/unit Average at 25°C
Self Discharge	SPA batteries can be stored for more than 6 months at 25°C. Please charge batteries before using. For higher temperature, the time interval will be shorter.
Terminal	Faston F3
Container Material	A. B. S. (UL94-HB) Flammability resistance of UL94-V2 can be available upon request.

## Dimensions



### Constant Current Discharge Characteristics Unit: A(25°C)

F.V/Time	5MIN	10MIN	15MIN	30MIN	1HR	2HR	3HR	4HR	5HR	8HR	10HR	20HR
1.60V	74.7	50.0	38.4	21.1	12.5	7.49	4.61	3.78	3.04	2.23	1.76	0.99
1.67V	69.9	46.6	36.1	20.8	12.4	7.43	4.59	3.76	3.02	2.23	1.75	0.95
1.70V	66.2	45.2	35.3	20.6	12.3	7.42	4.57	3.74	3.01	2.23	1.73	0.94
1.75V	59.8	42.3	33.4	20.2	12.2	7.33	4.55	3.73	2.99	2.23	1.71	0.90
1.80V	53.4	39.4	31.6	19.7	12.0	7.20	4.52	3.71	2.97	2.21	1.67	0.86
1.85V	47.0	36.5	29.7	19.2	11.8	7.09	4.48	3.69	2.95	2.21	1.66	0.85

### Constant Power Discharge Characteristics Unit: W(25°C)

F.V/Time	5MIN	10MIN	15MIN	30MIN	1HR	2HR	3HR	4HR	5HR	8HR	10HR	20HR
1.60V	144	93.6	76.1	42.2	25.0	15.0	9.20	7.52	7.15	4.48	3.51	1.96
1.67V	135	90.0	72.2	41.5	24.9	14.9	9.18	7.51	7.09	4.48	3.47	1.89
1.70V	132	87.3	70.5	41.3	24.8	14.8	9.16	7.51	7.07	4.45	3.44	1.85
1.75V	120	83.7	66.8	40.3	24.4	14.6	9.11	7.45	7.06	4.43	3.40	1.78
1.80V	107	78.3	63.1	39.3	24.0	14.4	9.04	7.40	7.04	4.41	3.35	1.73
1.85V	94.1	72.9	59.5	38.4	23.6	14.2	8.96	7.34	7.02	4.41	3.29	1.67

All mentioned values are average values.

### Temperature effects curve

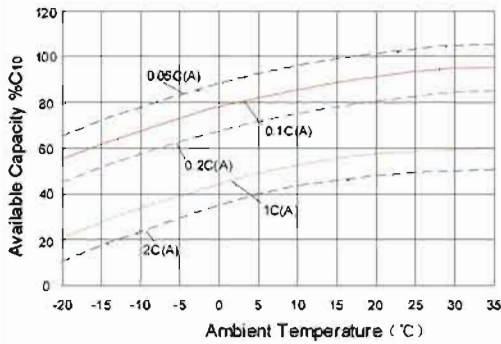

### Storage characteristic

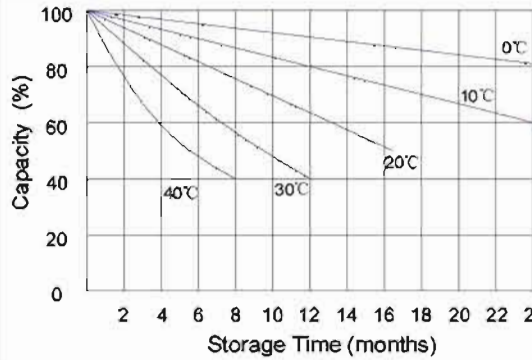

Supplementary charge required (Carry out supplementary charge before use if 100% capacity is required)

Supplementary charge required before use. This supplementary charge will help to recover the capacity and should be made as early as possible.

Supplementary charge may often fail to recover the capacity. The battery should never be left standing till this state is reached

Supplementary charge and storage guidelines

### Life characteristics of cyclic use

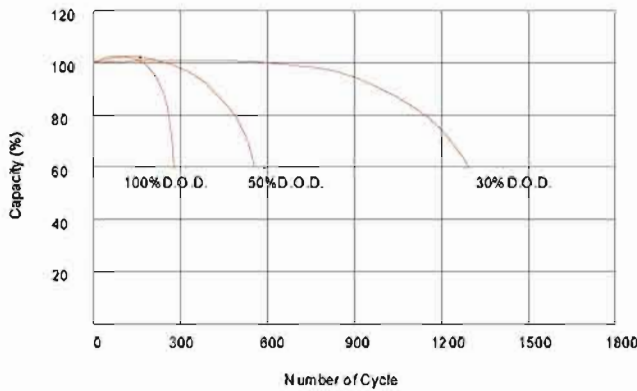

### Effect of temperature on long term float life

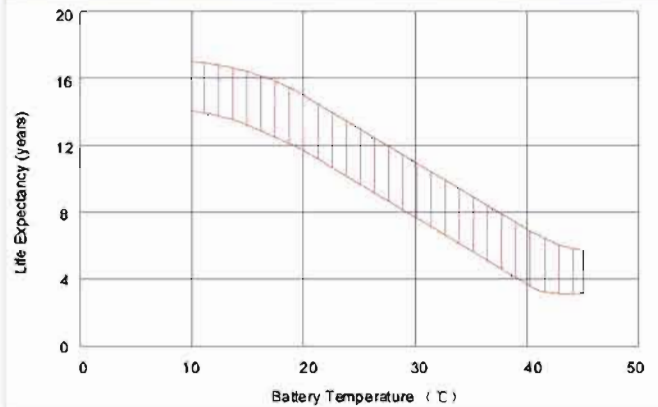

### Charge characteristic Curve for standby use

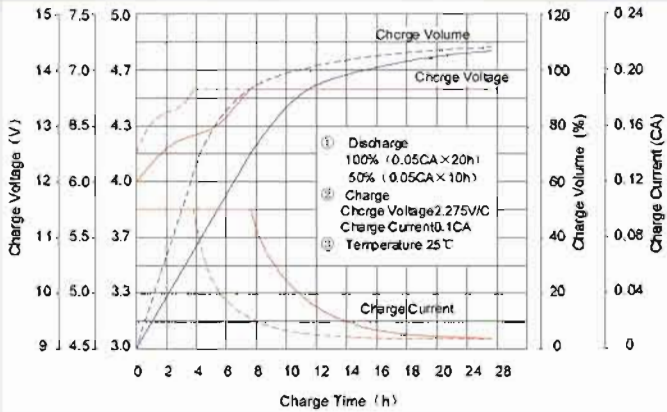

### Discharge characteristic Curve

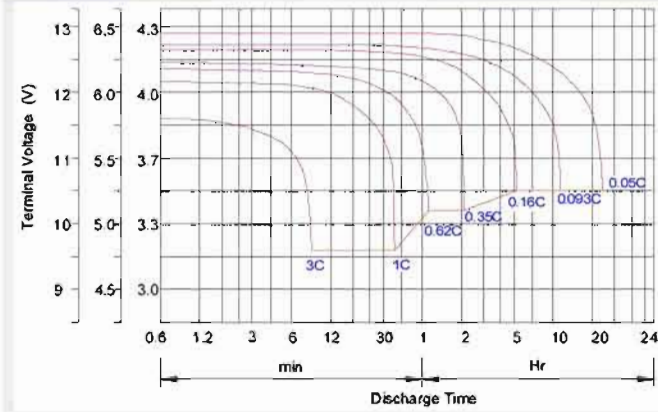

### Charging Procedures

Application	Charge Voltage (V)			Max. Charge Current
	Temperature	Set point	Allowable range	
Cycle Use	25°C	14.7	14.5~14.9	0.3C
Standby	25°C	13.7	13.6~13.8	0.3C

### Discharge Current VS. Discharge Voltage

Final Discharge Voltage V/cell	1.75V	1.70V	1.60V
Discharge Current (A)	(A) ≤ 0.2C	0.2C < (A) < 1.0C	(A) ≥ 1.0C

Charge the batteries at least once every six months, if they are stored at 25°C.

Charging Method:

Constant Voltage	14.5~14.9V, 5~11h, Max. Current 0.3CA
------------------	---------------------------------------