

HGL3.3-6

Valve Regulated Sealed Lead-Acid Battery

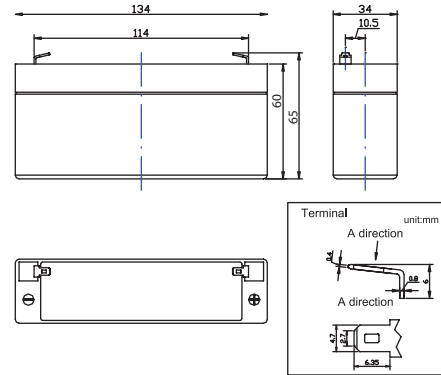

Dimensions (mm)



Specifications

Nominal Voltage		6 V
Rated Capacity (20 hours rate)		3.3Ah
Dimensions (± 2mm)	Total Height (with terminals)	65mm
	Length	134mm
	Width	34.5mm
	Height	60mm
Approx. Weight		0.70kg
Terminal	Standard	F1
	Optional	

Characteristics

Capacity (25°C)	10 hour rate (298mA)	2.98AH	
	5 hour rate (585mA)	2.72AH	
	1 hour rate (1.92A)	1.92AH	
	15 min rate (5.6A)	1.4AH	
Internal Resistance	Fully charged Battery 25°C	Approx. 40m	
Capacity affected by temperature (20 hour rate)	40°C	102%	
	25°C	100%	
	0°C	85%	
	-15°C	65%	
Self Discharge (25°C)	Capacity after 3 months storage	91%	
	Capacity after 6 months storage	82%	
	Capacity after 12 months storage	64%	
Charge Method (Constant Voltage)	Cycle use	Initial Current	0.8A or smaller
		Control Voltage	7.25 to 7.45V (25°C)
	Standby use	Initial Current	0.8A or smaller
		Control Voltage	6.8 to 6.9V (25°C)

Constant wattage discharge (Watts/battery@25°C)

EV/CELL	5min	10min	30min	1H	3H	5H	8H	10H	20H
1.85V	37.0	29.2	15.4	9.9	4.5	2.9	2.0	1.7	0.8
1.80V	46.3	33.9	17.2	10.5	4.6	3.0	2.0	1.7	0.9
1.75V	48.2	34.1	17.8	10.8	4.8	3.1	2.1	1.7	0.9
1.70V	51.5	35.6	18.2	11.2	4.8	3.5	2.1	1.8	0.9
1.60V	56.4	38.4	18.8	11.5	4.9	3.5	2.1	1.8	1.0

Discharge Characteristics

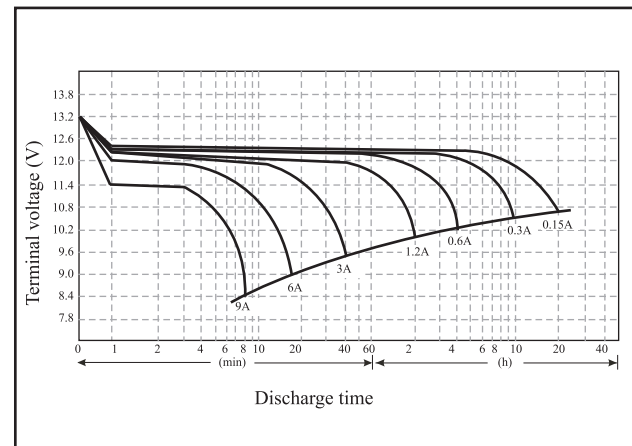

Discharge current & Duration Time

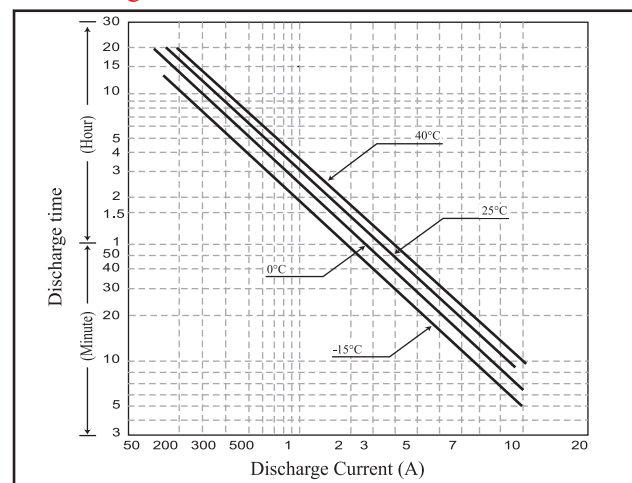

* The above data are average and obtained within three charge/discharge cycles. Cycles not the minimum values.